



Bulletin 2024-03

Subject: CARS Technical Rules Section 12 update including change to P4WD & P2WD.

Issue Date: September 23, 2024

Implementation: Two-Week Review – Comments accepted until October 7, 2024

Rationale:

CARS implemented the current class structure 10+years ago allowing for Open and Production Classes in both 4WD and 2WD. At the time the production classes were designed allowing competitors to run competition vehicles that were close to stock with only minor performance modifications, plus the addition of safety and durability equipment.

CARS recognizes that over the years production vehicles have become a lot less useable as rally cars under the current production class rules. This can be seen by the relatively small number of Production class entrants in our rallies and no newer vehicles to speak of.

The attached rule proposal changes the intent of the production classes from close to stock production, to allow a more prepared or modified car, meaning that many more modern cars can be converted to a **Prepared 4WD** or **Prepared 2WD** competition vehicle, while maintaining the highly modified **Open 4WD** and **Open 2WD** classes that are still a big step up in allowed performance modifications.

We propose maintaining the P4WD and P2WD designation, however the P would now stand for Prepared instead of Production.

Currently many competitors are forced into Open class when in reality they have relatively few modifications compared to what Open class allows. The proposed rules should allow a number of current competition vehicles that have been running as Open class, to run as a Prepared class competition vehicle along with hopefully a few more modern vehicles that will be able to compete because of the allowed modifications. Resulting in 4 meaningful classes that are more equally subscribed to.

As well as the above-mentioned changes the clauses on boost limits and boost monitoring have been modified and would be implemented as part of the changes to section 12.

With no direct manufacturer support for the championship the previous restriction on cross platform cars in the Open classes would be eliminated under this proposal. This would open the doors to other cross platform vehicles. (Cross Platform means Engine and Chassis can be from different manufacturers)

Section 12 Technical Rules has been simplified by moving some repeated clauses to the general regulations section and a summary table has been added so that all of the performance elements such as boost, displacement, weight, etc. are displayed in one place for the various classes. FIA cars are included in the table, slotted into the appropriate class.

We are proposing a January 2025 implementation since none of the rule changes require existing cars to be modified and can therefore compete in the revised classes. Modifications being proposed are mostly an opening up of the P4WD and P2WD classes as we move away from a Production bias to a more Prepared bias. Any changes to vehicles can be undertaken over time if so desired.

Finally, these proposed rule changes bring CARS into closer alignment with the ARA Open and Limited classes hopefully making it easier for competitors to cross border compete.

Please submit your comments by <date> to Debbie Dyer at the CARS office Email: office@carsrally.ca

Debbie will provide all comments to the board for review, consideration and adjustments to the proposed rule changes before a final version is issued.

NOTES ABOUT ATTACHED SECTION 12 SHOWING RULE CHANGES:

1. In the attached copy of section 12, clauses read as if section 1 – Ignore as this will correct when inserted back in the rule book.
2. The linked references show up in this copy of section 12 with “**Error! Reference source not found**” ignore as this will correct when inserted back in the rule book.

TECHNICAL RULES - 12



1 ELIGIBILITY OF VEHICLES AND EQUIPMENT

1.1 APPLICATION

1.1.1 These regulations shall apply to vehicles competing in rallies which contain special stages.

1.1.2 Vehicles must comply with these regulations at all times during the competition.

1.2 DEFINITIONS

1.2.1 Chassis - Bodywork.

- a) Interior bodywork: cockpit and trunk;
- b) Exterior bodywork: All the entirely suspended parts of the vehicle licked by the airstream;
- c) Chassis: The overall structure of the vehicle around which are assembled the mechanical components and the bodywork including any structural part of the said structure.

1.2.2 Model.

A model is a basic manufacturer's designation (e.g.: Subaru Impreza, Volkswagen Golf, Ford Focus, Mitsubishi Lancer, etc...).

1.2.3 Model variant.

A model may exist in several variants as to bodywork (i.e.: 2 door sedan, 4 door sedan, coupe, SUV, etc.) or about mechanical components (e.g.: WRX, WRX Sti, etc.).

1.2.4 Original equipment.

Original equipment is all items of standard or optional equipment that could have been ordered with any particular bodywork variant of the model, installed on the factory production line and delivered through a dealer in Canada. This does not include special orders, "one-offs" or pre-production vehicles. Dealer installed options, except as required by manufacturer directives (no matter how common), are not included in this definition.

1.2.5 Generation

A generation is a model's particular design offered during a specific year or number of consecutive years. After producing an original model (e.g. First Generation: 1993 – 2001 Subaru Impreza, 1976 – 1979 Mitsubishi Lancer, 1998 - 2005 Ford Focus, etc.) manufacturers may develop significant changes or totally redesign the original model after producing it for a number of years, they classify this new/next design as the next generation of that model (e.g. 2nd. Generation: 2002 - 2007 Subaru Impreza, 1979 – 1987 Lancer, 2005 - 2011 Ford Focus, etc.)

1.3 SAFETY REGULATIONS

1.3.1 Road worthiness.

1.3.1.1 All competing vehicles must be roadworthy and, the following items in particular must be adequate and functioning properly:

- a) All brakes;
- b) Horn;
- c) Windshield wipers;
- d) All legally required exterior lights;
- e) Tires, including all spares;
- f) Exhaust system.

1.3.1.2 For each crew, a signed, self-declaration will be submitted at registration or virtually that the competition vehicle is road worthy and the above items are operating properly.

1.3.2 Roll Over Protection.

1.3.2.1 Roll cages are mandatory for all vehicles.

1.3.2.2 Specific roll over protection is subject to the approval of the scrutineer at each event.

1.3.2.3 Basic design considerations.

The basic purpose of the roll over protection is to prevent serious bodyshell deformation, and so reduce the risk of injury to occupants in the case of a collision or of a vehicle turning over. The essential features of safety cages are sound construction designed to suit the particular vehicle, adequate mountings and a close fit to the bodyshell. The safety cage must not unduly impede the entry or exit of the driver and co-driver.

All new vehicles with log-books issued after January 1, 2009 must be fitted with a safety cage built to FIA Article 253 specifications or be FIA homologated under the latest international regulations and accompanied by original certification documentation (older homologated cages are not all valid for a newly built vehicle).

See www.fia.com, under Sport, Regulations, International Sporting Code, Appendix J (at bottom), Article 253, Article 8.

1.3.2.4 Alternate material to CDS (Cold Drawn Seamless):

Although FIA Article 253.8.3.3 specifies the safety cage material as CDS (Cold Drawn Seamless), DOM (Drawn Over Mandrel) tubing may be used as an alternate material in respect to the following: main roll bar, front roll bar, lateral roll bars, lateral half roll bars,

their connections (drawings 253-1-3) and one continuous door bar per side will be at least 1.75"x.095". All other parts of the safety cage will be at least 1.5" x 0.095".

1.3.2.5 Approval of Safety cages:

A material certificate or an original sales receipt detailing the material used to fabricate the safety cage must be presented. For every tube size used in the fabrication of the safety cage, an unpainted sample section, 45cm long and bent 60 degrees must be presented as part of the initial inspection per CARS Technical Rule 1.9.4.1.

1.3.2.6 Protective Padding:

Where the occupants' bodies could come into contact with the safety cage, flame retardant padding must be provided for protection.

Where the occupants' crash helmets could come into contact with the safety cage, the padding must comply with FIA standard 8857 2001, type A (see technical list n 23 "Roll Cage Padding Homologated by the FIA") or SFI 45.1.

1.3.3 Safety Harness.

1.3.3.1 Five or six point safety harness of unmodified proprietary manufacture, meeting the specifications below, shall be fitted for both crew members:

- a) FIA Standard 8853/98 & 8853-2016;
- b) SFI 16.1;
- c) SFI 16.5.

FIA homologated harness sets must not be used in competition after the expiration date on the label affixed to the harnesses. SFI licensed harness sets must have a date of manufacture label that is no older than two years.

Note: It is not permitted to mix parts of seat belts. Only complete sets may be used.

1.3.3.2 The material of all straps shall be in new or perfect condition. The belts must be equipped with turn buckle or push button release systems.

1.3.3.3 The lap belt and crotch straps should not pass over the sides of the seat, but through the seat in order to wrap and hold the pelvic region over the greatest possible surface.

The lap straps must fit tightly in the bend between the pelvic crest and the upper thigh. Under no circumstances may they be worn over the region of the abdomen.

Care must be taken that the straps cannot be damaged through chafing against sharp edges.

1.3.3.4 In all cases, it is most preferable that safety harnesses be installed on the anchorage points of the vehicle. The recommended geometrical locations of the anchorage points

are shown in drawing 253-42. It is prohibited for the seat belts to be anchored to the seats or their supports.

- 1.3.3.5 The shoulder harness shall be a two-strap over-the-shoulder type. ("H" type configuration is permitted.) In the downwards direction, the shoulder straps must be directed towards the rear and must be installed in such a way that they do not make an angle of more than 45° to the horizontal from the upper rim of the backrest. However, it is recommended that this angle should not exceed 10°. The maximum angles in relation to the centre-line of the seat are 20° divergent or convergent. (see diagram 253-42) Anchorage points creating a higher angle to the horizontal must not be used unless the seat meets the requirements of the FIA standard. (If the seat does not provide lateral restraint, the mounting point on the vehicle structure shall be a minimum of 50 cm behind the seat back when measured along the belt.)
- 1.3.3.6 If the manufacturer provides for safety wiring the locking bale to prevent accidental unfastening of the belts from their anchorage points, then it shall be necessary for all such components to be safety wired.
- 1.3.3.7 The minimum acceptable size and grade of bolt used in the mounting of all belts and harnesses shall be 7/16-inch UNF, SAE grade 8 or, preferably, M12 8.8. When mounted, the bolts should work in shear and not in tension.
- 1.3.3.8 If installation on the series anchorage points is impossible for the shoulder and/or crotch straps, new anchorage points must be installed on the shell or the chassis, as near as possible to the centre-line of the rear wheels for the shoulder straps. The shoulder straps may also be fixed to the safety roll cage or to a reinforcement bar by means of a loop, and may also be fixed to the top anchorage points of the rear belts, or be fixed or leaning on a transversal reinforcement welded to the backstays of the roll bar. In this case, the use of a transversal reinforcement is subject to the following conditions:
- The transversal reinforcement shall be a tube measuring at least 38 (1.5") mm x 2.5 mm or 40 (1.6") mm x 2 mm, made from cold drawn seamless carbon steel, with a minimum tensile strength of 350 N/mm².
- The height of this reinforcement must be such that the shoulder straps, towards the rear, are directed downwards with an angle of between 10° and 45° to the horizontal from the rim of the backrest, an angle of 10° being recommended.
- The straps may be attached by looping or by screws, but in the latter case an insert must be welded for each mounting point (see drawings 253-17C and 253-53 for the dimensions). These inserts will be positioned in the reinforcement tube and the straps will be attached to them using bolts of M12 8.8 or 7/16 UNF specification.

Each anchorage point must be able to withstand a load of 1470 daN, or 720 daN for the crotch straps. In the case of one anchorage point for two straps, the load considered will be equal to the sum of the required loads.

For each new anchorage point created, a steel reinforcement plate with a surface area of at least 40 cm² and a thickness of at least 3 mm must be used.

1.3.3.9 Principles of mounting to the chassis/monocoque:

- General mounting system: see drawing 253-43;
- Shoulder strap mounting: see drawing 253-44;
- Crotch strap mounting: see drawing 253-45.

1.3.3.10 A safety harness must be used in its homologation configuration without any modifications or removal of parts and in conformity with the manufacturer's instructions. The effectiveness and longevity of safety belts are directly related to the manner in which they are installed, used and maintained. The belts must be replaced after every severe collision, and whenever the webbing is cut, frayed or weakened due to the actions of chemicals or sunlight. They must also be replaced if metal parts or buckles are bent, deformed or rusted. Any harness which does not function perfectly must be replaced.

1.3.4 Fire extinguishers.

1.3.4.1 Two fire extinguishers with a minimum UL rating of 5 BC each, must be installed inside the passenger compartment. During installation, consideration must be given to quick release and security of attachment. One fire extinguisher must be located within easy reach of the Driver or Co-Driver when seated.

Quick release metal fastenings (two minimum), are required, as are anti torpedo tabs. FIA approved mounts are recommended, but any mountings installed should be able to withstand a deceleration of 25g **in any direction.**

1.3.4.2 An on-board Extinguishing System is highly recommended per FIA Standard 8865-2015 (SFI Spec 17.1 systems acceptable). The System must be mounted according to the manufacturer's instructions and only metal piping is permitted. Minimum quantity of extinguishant must be 3kg.

The mountings should be able to withstand a deceleration of 25g **in any direction.** Furthermore, only metal fastenings (two minimum), are acceptable. Anti-torpedo tabs are required.

In addition to an extinguishing system, two fire **extinguishers** per 12.4.3.1 **3.4.1** are required.

1.3.4.3 Evidence must be produced that the fire extinguisher has been purchased recharged or inspected by a certified fire extinguisher inspector within the preceding two years.

1.3.4.4 A fire extinguisher label (available through CARS) must be placed on the outside of the vehicle, on a non-glass surface, at the nearest point of access to a fire extinguisher.

1.3.5 First aid kit.

A comprehensive first aid kit shall be carried in the passenger compartment. The first aid kit must include:

- 10 Cleansing Wipes,
- 25 Adhesive Bandages 1.9cmx7.5cm,
- Knuckle Bandages,
- 4 Fingertip Bandages,
- 2 Gauze Pads 5cmx5cm,
- 3 Gauze Pads 7.5cmx7.5cm,
- 3 Gauze Pads 10cmx10cm,
- 1 Elastic Gauze Bandage 5cm x 4.5m,
- 1 Elastic Gauze Bandage 7.5cm x 4.5m,
- 1 Pressure Bandage 10cmx10cm,
- 1 Abdominal Pad 12cmx22cm,
- 2 Oval Eye Pads,
- 10 Butterfly Closures,
- 6 Cotton Tip Applicators,
- 1 Tongue Depressor,
- 2 pair Vinyl Gloves,
- 1 pair Scissors 14cm,
- 1 First Aid Pocket guide,
- 1 Adhesive Tape 2.5cm x 4.5m,
- 1 pair Tweezers,
- 1 Cold Compress,
- 3 Triangular Bandages,
- 2 Space Blankets.

In addition, it is recommended to carry a CPR mask, if the competitor is trained in its use.

The first aid kit must be easily accessible, clearly identified and the complete kit easily/quickly removable by hand. It is recommended that the first aid kit be accessible from both sides of the vehicle and from the seated position.

A first-aid kit label (available through CARS) must be placed on the outside of the vehicle, on a non-glass surface, at the nearest point of access to a first-aid kit.

1.3.6 Warning devices.

Three self-supporting, light-reflecting, daylight-visible triangular warning devices of a minimum size of 30 cm per side shall be carried in the vehicle. One of which must be located within easy reach of the Driver or Co-Driver when seated.

1.3.7 Batteries.

1.3.7.1 Batteries must be securely mounted **and have non-conductive covers over the terminals.**

1.3.7.2 If removed from the original location, all batteries shall be mounted inside covered, non-conductive boxes.

1.3.7.3 If mounted inside the passenger compartment, batteries shall be those that are completely sealed or so designed or modified to prevent acid spillage.

1.3.8 General circuit breaker.

1.3.8.1 A spark-proof general circuit breaker with the capability of disconnecting all electrical circuits is required. A means of disconnecting all circuits, including the fuel pump, shall be mounted in the passenger compartment. Additionally, the fuel pump must shut off with the ignition switch.

1.3.8.2 The location of the circuit breaker shall be that which makes it easily operable by either crew member or by persons outside the vehicle through either front door.

1.3.8.3 The location of the circuit breaker control shall be clearly identified.

1.3.8.4 A single circuit, protected by a 5A fuse, is permitted to power the Vehicle Tracking System.

1.3.9 Windows.

1.3.9.1 The windshield shall be laminated safety glass.

1.3.9.2 ~~In all classes, it is permitted and encouraged to replace electric winders with manual ones. In all cases~~ The competitor must be able to describe to the satisfaction of the event scrutineer the ability to escape from the vehicle with the doors closed.

1.3.9.3 Windows in the driver and co-driver doors must not be rolled down more than 2.5 cm during stages. ~~Window safety nets must be used in lieu of having windows rolled up during stages. (See illustration for proper window net installation). It is highly~~

recommended that all window nets meet FIA article 253.11. *Delete Diagram*

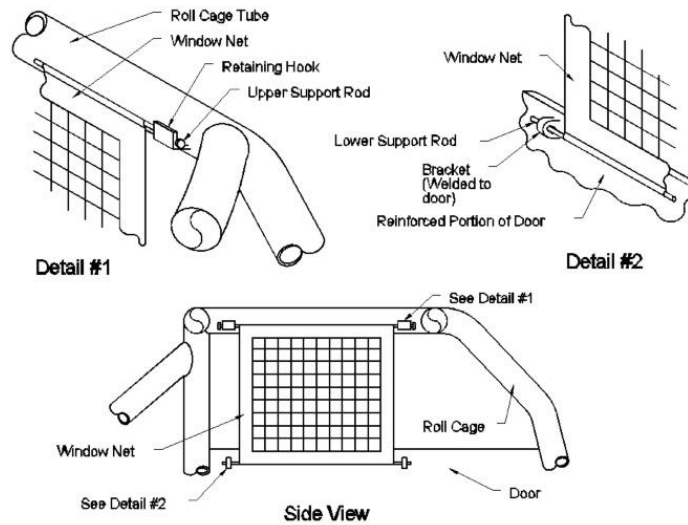

1.3.9.4 The use of translucent and colourless anti-shatter films is highly recommended in side and rear windows. The use of silvered or tinted anti-shatter films is also permitted. In all cases, the maximum tint shall be 50.

1.3.9.5 For vehicles in Open 4WD and Open 2WD, It is permissible to replace glass side windows with Lexan of like or greater thickness than the original glass. However, competitors must be able to display to the satisfaction of the event scrutineer that the mounting of the substitute windows will allow both emergency escape from inside the vehicle and access by rescue from the outside of the vehicle.

1.3.10 Mud flaps.

Mud flaps are required on all rear wheels and driving wheels.

1.3.11 Fuel, fuel tanks and lines

1.3.11.1 Only unleaded fuels are allowed. ~~Leaded fuel and lead additives are expressly prohibited.~~

1.3.11.2 A fuel-resistant and fire-retardant plate or shield is required between the passenger compartment and the compartment or area in which the fuel tank, fuel filler and fuel pump is located.

All fuel tanks and fuel cells must be securely mounted to the vehicle. Any fuel tank or fuel cell surface exposed on the bottom of the vehicle shall be equipped with a shield designed to prevent puncture or damage from stones, debris and abrasion.

1.3.11.3 The original fuel tank may only be replaced by an FIA- or SFI- approved fuel cell provided that:

- a) The original fuel tank is removed.
- b) The fuel cell is properly vented to outside the vehicle from the compartment in which it is located.
- c) The original fuel filler opening is sealed, if not used for the fuel cell.
- d) Should the fuel cell and its filler be located in the luggage compartment, an outlet must be provided for fuel spilled in the compartment.
- e) Where fuel cells are installed in the passenger compartment of vehicles such as "hatchback" variants, CARS Technical Rule 1.3.11.2 above applies if the fuel cell filler is in the passenger compartment **unless it is equipped with quick connects**. Supplementary fuel tanks are not permitted.

1.3.11.4 If fuel lines are re-routed through the passenger compartment, they shall be in compliance with the following:

- a) Shall incorporate a metallic casing (If the metallic casing is not exterior to the line, a verifiable sample must be presented at scrutineering);
- b) Shall have a minimum of 200 psi rating. (If fuel lines are routed through the passenger compartment by the manufacturer, it is recommended that they be in compliance with this section).

1.3.11.5 Fuel pumps shall be isolated from the driver/co-driver by a fireproof metal bulkhead.

1.3.11.6 All the fuel pumps must only operate when the engine is running, except during the starting process.

1.3.12 Seats and seat mountings.

1.3.12.1 Seats:

- a) Use of hinged-back and OEM seats is prohibited;
- b) All the occupants' seats must be homologated by the FIA standards 8855-1999 or 8862-2009, 8855-2021 and not modified;
- c) It is recommended that seats be replaced after 5 years from the date of manufacture. Seats older than 10 years from date of manufacture must be replaced.

1.3.12.2 Seat Mounting:

- a) Seats must be such that they are securely attached to the floor of the vehicle in such a manner as to prevent the movement of the seat in case of an accident. All seats must be mounted as per FIA Appendix J, Article 253, Article 16: Seats, Anchorage points and Supports. End plates may be fully welded instead of bolted.
- b) Vehicles log booked prior to June 1, 2011 or requiring alternative seat mounting are subject to the approval of the CARS Technical Director or his designate.

1.3.13 Towing eyes.

- a) Competition vehicles must be equipped with a metal tow eye on the front and rear of the vehicle
- a) The tow eyes must be identified by a "TOW" sticker, and be painted yellow, red or orange.
- b) The tow eyes must have a minimum internal diameter of 3/4"
- c) The tow eye must be of sufficient strength to support the weight of the vehicle during a recovery operation, and must be in good condition.

1.3.14 Loose articles.

All articles which could be dangerous if left loose must be securely restrained.

1.3.15 Door panels.

Inside door panels are required to provide protection from metal edges.

1.3.16 Tow Strap.

All vehicles must carry a recovery strap. All parts of the recovery strap must be within the competition vehicle at all times while the recovery strap is not in use.

1.3.17 Roofs.

Movable metal sunroofs and/or roof panels must be fixed in the closed position. Sunroofs and/or roof panels of any other material must be replaced with metal and must be fixed in the closed position. The finished work must be of equal or greater strength than the permanent roof.

1.3.18 Supplemental & Passive Restraints.

Airbags and their associated equipment must be disabled or removed during competition in order to eliminate the possibility of the airbag inflating accidentally. It is recommended that passive restraint systems be disabled.

1.3.19 Ground Clearance

All parts of the vehicle, other than the tires, must have a minimum of 5.0 cm clearance from a level road surface.

1.3.20 Power Door Locks

For all classes, ~~it is recommended that~~ power door locks **shall** be rendered inoperative and replaced with manually operated mechanisms.

1.3.21 Steering Locking Device

For all classes, ~~it is recommended that any~~ steering locking device **shall** be rendered inoperative.

1.3.22 Camera and Camera Mounts

Camera mounts and their attachment to the vehicle shall be of a safe and secure design which would prevent either driver from being able to strike any part of the mount. As well, the camera shall be secured at a minimum of two different points and neither attachment may be elastic or plastic.

1.3.23 Belt Cutters

One or more belt cutters must be carried in the vehicle within reach of both driver and co-driver while safety harnesses are being worn. The seat belt cutter must be designed specifically for cutting seat belts.

1.3.24 Window Breakers

One or more window breakers must be carried in the vehicle within reach of both driver and co-driver while safety harnesses are being worn. The window breaker must be capable of breaking the windshield or glass side windows to provide egress and should be secured against movement.

1.3.25 Spill Kit

All competition vehicles must carry a spill kit consisting of at least: a minimum of 2 -15" x 19" (standard) absorbent pads, 1- 3" X 48" Hydrocarbon sock. All items will be contained in a heavy-duty plastic bag that is re-sealable.

1.4 GENERAL REGULATIONS

1.4.1 Bodywork.

1.4.1.1 Exterior bodywork (i.e.: all components licked by the airstream) must be visually similar to the original item. Except for front doors, including door reinforcement bars and roof.

1.4.1.2 Bolt-on body pieces may be constructed of an alternate material.

1.4.1.3 A and B pillars must remain original. The original floor pan and firewall must remain and may be modified only to the extent necessary to accommodate allowed alternate components.

1.4.1.4 Roof mounted vents, flared fenders, modified front and rear bumper covers are allowed.

1.4.1.5 Bodywork must be without visible damage or perforation from corrosion which would detract from the good appearance of the vehicle.

1.4.1.6 ~~The general shape and location of bumpers may not be changed.~~

1.4.1.7 If original exterior trim is removed, all mounting holes must be completely filled.

1.4.1.8 Paintwork must be finished and of neat appearance. Primer paint is not acceptable.

1.4.2 Vehicle and Crew Identification

12.4.2.1 Vehicle graphics standards

All competing vehicles in stage events shall be identified in accordance with the CRC Visual Package standard, described on the CARS website.

12.4.2.2 Competition Vehicle Permanent Numbers

Drivers are required to reserve a permanent vehicle number from the CARS office in accordance with the CARS Competition Vehicle Number reservation policy, described on the CARS website.

12.4.2.3 Competitor Identification

The name of the driver and the co-driver must appear on the rear side windows of the vehicle as shown in the diagram. The national or provincial flag of each crew member must appear adjacent to the name and be 5 cm/ 2 inches high.

Only if the driver and co-driver names and flag do not fit on the rear window, an alternative location such as the front fender or roof can be used.

The letters of the driver's name must be white, 5 cm / 2 inches in height in upper- and lower-case Helvetica bold face. The letters of the names must be the same size.

12.4.2.4 Windscreen Banner

The top 15.2 cm / 6 inches of the windscreen is reserved for use by CARS and/or its sponsors. No other advertising is permitted anywhere on the windscreen. Door Reserved Space

An area 61 cm / 24 inches wide by 51 cm / 20 inches high, starting with the lead edge of the doors and from the top of the door panel downwards shall be reserved for exclusive use for the installation of the CARS door panels and event sponsor decal.

The CARS door panel is 24" wide x 10" high. The maximum size of event sponsor decal that can be installed under the door panel is 23" wide x 9" high.

12.4.2.5 Bumper Reserved Space

An area, 30.5 cm / 12 inches wide and 10 cm / 4 inches high, on each of the front, lateral left and right sides of the front bumper skin shall be reserved for exclusive use by CARS and/or its sponsors. If there is insufficient area on the front bumper or lower valance to support the sponsor identification, then an equal area on the leading edge of both front fenders shall be reserved. Additionally, no conflicting sponsor identification may be displayed on the front below the hood edge (or on the front fenders if that option is used).

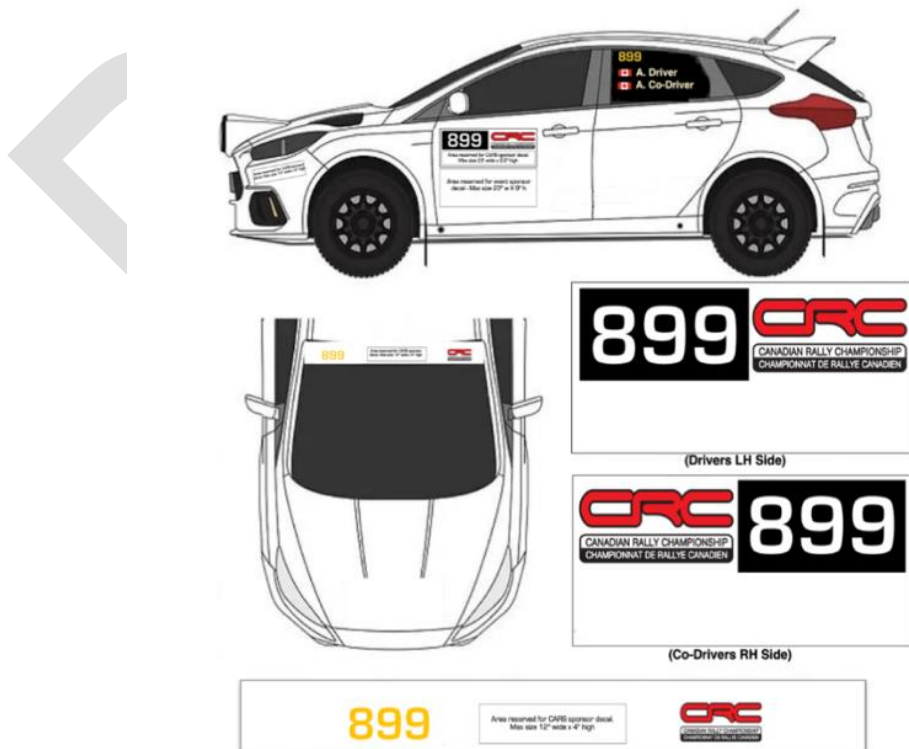

1.4.3 Lights.

- 1.4.3.1 Original headlights may not be changed or removed. However, the frontal glass, reflector and bulbs are free provided they are in compliance with the legal requirements of the province or state of registration.
- 1.4.3.2 A headlight shall be considered as any lighting device throwing a beam toward the front of the vehicle (dipped-beam, long range lamp, anti-fog lamp). Auxiliary headlights may be fitted. These lights may be fitted into the bumpers, radiator grillwork or the front part of the bodywork, provided that such openings as needed in this case are completely filled by the lights fitted.
- 1.4.3.3 It must be possible to turn off all high-beam headlights and auxiliary lights with a single switch, which must leave the low-beam headlights functioning.
- 1.4.3.4 It must not be possible to operate any fog lights fitted without the front marker lights and tail lights operating.
- 1.4.3.5 Auxiliary reversing lights may be fitted. They may be embedded in the rear bodywork if necessary.
- 1.4.3.6 All reversing lights may only switch on by engaging reverse gear.
- 1.4.3.7 It is not permitted to fit any device which can alter the normal functioning of the brake lights.
- 1.4.3.8 The mounting of maneuverable search lights is prohibited.

1.4.4 Studded tires.

- 1.4.4.1 Studded tires are permitted at winter events in jurisdictions that permit the use of studded tires if so defined in the event supplementary regulations. In events that are comprised of a National event and a Regional event concurrently, the supplementary regulations are to define the usage of studs for each event.
- 1.4.4.2 Studded tires produced by a tire manufacturer (such as the Nokian Hakkapeliitta 8), that are North American DOT approved for use on public roads may be used (competition tires may only be used in accordance with 12.4.3.3). These tires must retain, the original number and type of stud installed at time of manufacture and must not be modified. It is the entrant's responsibility to provide supporting documentation of stud type and stud count for any such tire.
- 1.4.4.3 Tires in which studs are installed subsequent to the manufacturing process may also be used and the following conditions must be met:

- a) Studs must protrude no more than 3.5mm from the tread face, and meet the Tire stud Manufacturers Index (TSMI) specifications on size 12, 13, 15 or 16 (see TSMI appendix). Stud construction shall have a single base flange, a cylindrical body, and carbide tip with maximum diameter of 2.5mm;
- b) The studs must be mounted in tires that are designated by the manufacturer as studdable and are produced with moulded holes for the purpose of stud retention;
- c) There may only be a maximum of 130 studs per tire, regardless of tire size;
- d) Adhesive may be used to affix the stud into the tire;
- e) Homemade, competition, specialty, off road or custom studs are not permitted;
- f) Studs are permitted in all classes.
- g) Studded tires must be presented at scrutineering and marked by the scrutineer as approved for use in the event. Studs may be pulled as required to determine the type and size.
- h) Unmarked studded tires used during the event will be penalized per NRR17.2

1.4.4.4 Chains or other devices attached to or inserted into a tire are not permitted.

1.4.4.5 The penalties for violation of the above studded tire regulations are as per CARS NRR **Error! Reference source not found.** and, for cases involving intentional circumvention of the studded tire regulations, CARS GCR **Error! Reference source not found.** c)



www.brunowessel.com

1.4.5 Exhaust system.

1.4.5.1 The maximum permitted noise level from the exhaust system during any transit shall be 94 dba from a distance of 3 meters (10 feet).

1.4.5.2 The maximum permitted noise level from the exhaust system with the engine idling at 3500 RPM and the vehicle stationary shall be 86 dba, measured from a distance of 15 meters (49 feet).

1.4.5.3 Unless a vehicle was legally registered before a catalytic converter was required in Canada, then a functioning catalytic converter must be retained or installed. (Burden of proof that a catalytic converter is not required for a particular vehicle rests with the competitor and should be furnished to the CARS technical director so that an exemption waiver may be added to the vehicle log book.)

1.4.6 Documentation.

The following documentation shall be carried in the vehicle at all times:

- a) Vehicle registration **and/or any applicable exemption documentation.**
- b) Proof of third-party liability insurance covering the entered vehicle.

1.4.7 ~~Vehicle numbers.~~

~~All competing vehicles in stage events shall be identified with the vehicle number in five locations: one on the co-driver's side of the windshield banner, one on each of the door panels and one on each of the rear side window glass. (see diagram) These numbers will be supplied to competitors by the event organizer.~~

1.4.8 U.S. vehicles.

Vehicles registered in any of the United States of America, where the driver is competing on CARS entry permit (See CARS NRR **Error! Reference source not found.**) shall be acceptable to compete in Canadian events if they meet the requirements of current ARA/NASA Rally Regulations. Entrants whose vehicles are entered under this provision must be able to produce, upon request by CARS or event officials, a copy of the relevant US Rally Regulations. Failure to produce these regulations may result in vehicle being judged according to CARS regulations.

US vehicles entered in Canadian rallies shall be classified by CARS vehicle class regulations. US Vehicles not in compliance with CARS class rules will be allowed to compete, but will not be eligible for Championship points. Competitors using these vehicles will be eligible for applicable contingency payouts and podiums.

[ARA to CARS class equivalency](#)

1.4.9 ~~Vehicle Eligibility~~

~~All vehicles must be based on production passenger cars or light trucks. Eligibility is restricted to vehicles based on street licensable, closed bodied passenger cars and light trucks. Non-production based vehicles that are of tube or box frame construction are explicitly forbidden.~~

1.4.10 Tire Coverage

Tires must be fully covered when viewed from above.

1.4.11 The installation of radar detection equipment is prohibited.

1.4.12 Restrictors

- Forced induction engines must have an air inlet orifice per class requirements. If the forced induction is equipped with a larger inlet, the use of a restrictor is required. It must have a minimum width (parallel to the direction of the airflow) of three (3) mm and be placed within 50 mm of the compressor blades.
- If a vehicle is fitted with multiple induction systems, then the total area of the two restrictors cannot exceed the area of the restrictor listed above.
- Competitors must have in place a mechanism to allow the induction system to be sealed by the use of wire and CARS seals.
- With the wire and seal in place, it must be impossible to access the restrictor without removing the wire and seal.
- The wire and seal cannot be installed without a detailed examination of the restrictor and, without the seal being in place.
- Competitors must be prepared to dismantle the induction system to allow for verification of compliance with the rule above.

1.4.13 Boost limits

- Boost is per class requirements
- If boost limits are required by the class then competitor to provide a 1/8" female pipe fitting in the intake manifold plenum for CARS use.
- CARS will use a boost monitor that will be installed on random competition cars to monitor the boost.
- The boost monitor can be installed by a CARS official at any time during the event and used to gather boost pressure data.
- The storage of boost (i.e. an accumulator) is not permitted.
- As an option to competitors, boost monitoring may be accomplished with an FIA pop-off valve installed per FIA Technical List n 43. FIA pop-off valves are to be sealed by CARS during the event scrutineering.

1.4.14 Weight

This is the real weight of the vehicle, without consumable fluids, with neither driver nor co-driver nor their equipment and with a maximum of one spare wheel. When two spare wheels are carried in the vehicle, the second spare wheel must be removed before weighing. At no time during the event may a vehicle weigh less than the minimum weight.

The use of securely fixed ballast to complete the weight of the vehicle is permitted.

In case of a dispute during weighing, the full equipment of the driver and co-driver must be removed.

Table A – Class Displacement, Restrictor, Boost & Weight					
CARS Class	Engine	Max Displacement	Restrictor	Boost	Min Weight
O4WD	Forced Induction	2500	34	2.5 Bar Abs	1318
	Forced Induction	FIA Rally 2 & 3 car homologated specs			
	Nat Aspirated	2500	none	na	1135
	Nat Aspirated	4000	none	na	1318
	Rotary	restricted to twin rotors			935
P4WD	Forced Induction	2500	33	2.5 Bar Abs	1409*
	Nat Aspirated	4000	none	na	1409*
	Rotary	restricted to twin rotors, additional porting not permitted			no min
O2WD	Forced Induction	2000 1800	32 none	Unlimited	no min 885
	Forced Induction	2500 2600	32 none	Unlimited	1136 995
	Forced Induction	2500 3500	none	unlimited	1318 1270
	Forced Induction	FIA Rally 4 & 5 car homologated specs			
	Nat Aspirated	4000 1800	none	na	no min
	Nat Aspirated	4000 4500	none	na	no min 950
	Rotary	restricted to twin rotors			no min
P2WD	Forced Induction	2500 1600	32 none	unlimited	Unlimited 1040
	Nat Aspirated	4000 2500	none	na	Unlimited 995
	Rotary	restricted to twin rotors, additional porting not permitted			no min

* unless OEM weight is less, **then allow that lesser weight.**

1.5 OPEN 4WD

1.5.1 Definition.

Any AWD or 4WD vehicle which meets the requirements of CARS Technical Rules 0 to 1.4, and 1.5.2 to **Error! Reference source not found.**

This includes vehicles of series or limited production, which are modified beyond what is permitted in Production 4WD. Innovation and modifications within the rules are encouraged, including modifying production based 2WD vehicles into 4WD rally vehicles.

1.5.1.1 FIA Vehicles [FIA Rally Pyramid](#)

The intent is that we limit the use of FIA homologated **Rally 1** cars in our overall championship ~~to the RC2 & RC3 Class Vehicles~~. This will be accomplished by not allowing RC1 Class, including World Rally or Rally 1 cars from 2017 – present, to compete in the championship or score points.

4WD FIA Homologated cars as per the FIA Rally Pyramid RC2 & RC3 classes, including Rally 2 and Rally 3 cars will be allowed to compete in the open 4WD class and score championship points as follows;

- a) RC2 & RC3 class cars must comply with their original homologation specifications with respect to powertrain, suspension, steering, brakes, aerodynamic components and vehicle weight, and comply with:
 - CARS Technical Rules 0 to 1.4, 1.5.2, 1.5.3 to 0,
 - CARS Technical Rules **Error! Reference source not found.**, 12.5.5 & **Error! Reference source not found.** use the homologation specification for the class of vehicle.
- b) World Rally & Class RC1 cars 2017 – present can participate in a Canadian Rally Championship event for the purpose of practice, demonstration or exhibition but will not be scored in the event nor will they collect any points.
- c) Pre-2017 World Rally cars are permitted to compete in open 4WD class and score points for the Canadian Rally Championship provided these FIA vehicles meet the homologation specifications for that particular vehicle's powertrain, suspension, steering, brakes, aerodynamic components and vehicle weight, and comply with:
 - CARS Technical Rules 0 to 1.4, 1.5.2, 1.5.3, 12.5.6 and 0,
 - The lesser of CARS Technical Rule **Error! Reference source not found.** or the homologated restrictor size,
 - The lesser of CARS Technical Rule **Error! Reference source not found.** or the homologated boost pressure limit,

- The greater of CARS Technical Rule **Error! Reference source not found.** or the homologated weight.
- d) Modified FIA vehicles that do not comply with the FIA regulations for their powertrain, suspension, steering, brakes, aerodynamic components and vehicle weight, but do comply with CARS O4WD class rules, will be eligible to compete and score points in Canadian Rally Championship events.

Any FIA vehicles will be required to have their complete homologation papers available at tech inspection.

1.5.2 Engine

The engine **manufacturer** is unrestricted, **see table A for class details.** ~~but must be derived from the product line offered by the vehicle manufacturer.~~

1.5.3 Bodywork.

1.5.3.1 Except for CARS Technical Rule **Error! Reference source not found.**, the modification, reinforcement, substitution, addition or deletion of parts and components is permitted without restriction.

1.5.3.2 Width:

- Maximum Width is OEM +10%
- Maximum allowable width is 2000mm including mirrors

1.5.3.3 Wings:

- Wings must not extend beyond the body work when viewed in plan
- Maximum height of wing is 76mm above the highest point of the roof

Technical inspector can reject wing installation on the basis of structural integrity.

1.5.4 Mechanical Components.

Brakes, carburettor/injection, transmission, suspension, cooling, final drive ratio and type, clutch, pressure plate and flywheel are unrestricted.

1.5.4.1 Sequential Gear Change.

The use of an unassisted manual sequential gear change mechanism is allowed.\

1.5.5 Electronic Controls.

No type or form of electronic control is permitted for the following components: suspension, braking, gear change/clutch, front and rear differentials. Simple engine cut operating during a mechanically activated gear change is permitted

DRAFT

1.6 OPEN 2WD

1.6.1 Definition.

Any 2WD vehicle which meets the requirements of CARS Technical Rules 0 to 1.4, and 1.6.2 to 1.6.5. This includes vehicles of series or limited production, which are modified beyond what is permitted in Production 2WD. Innovation and modifications within the rules are encouraged.

1.6.1.1 FIA Vehicles

2WD FIA Homologated cars as per the FIA Rally Pyramid RC4 & RC5 classes, including Rally 4 and Rally 5 cars will be allowed to compete in the open 2WD class and score championship points as follows;

- a) RC4 & RC5 class cars must comply with their original homologation specifications with respect to powertrain, suspension, steering, brakes, aerodynamic components and vehicle weight, and comply with:
 - CARS Technical Rules 12.1 to 12.4, 12.6.4 and 12.6.6
 - CARS Technical Rules 12.6.2, 12.6.3 and 12.6.5 use homologation specification for the class of vehicle.
- b) Modified FIA vehicles that do not comply with the FIA regulations for their class's powertrain, suspension, steering, brakes, aerodynamic components and vehicle weight, but do comply with CARS Open 2WD class rules, will be eligible to compete and score points in Canadian Rally Championship events.

Any FIA vehicles will be required to have their complete homologation papers available at tech inspection.

1.6.2 Engine and weight.

The engine **manufacturer** is unrestricted, **see table A for class details**. **but must be derived from the product line offered by the vehicle manufacturer**

1.6.3 Bodywork.

1.6.3.1 Except for CARS Technical Rule **12.4.1.1** the modification, reinforcement, substitution, addition or deletion of parts and components is permitted without restriction.

1.6.3.2 Width:

- **Maximum Width is OEM +10%**
- **Maximum allowable width is 2000mm including mirrors**

1.6.3.3 Wings:

- **Wings must not extend beyond the body work when viewed in plan**

- Maximum height of wing is 76mm above the highest point of the roof

Technical inspector can reject wing installation on the basis of structural integrity

1.6.4 Mechanical Components.

1.6.4.1 Brakes, carburettor/injection, transmission, suspension, cooling, final drive ratio and type, clutch, pressure plate and flywheel are unrestricted.

1.6.4.2 Sequential Gear Change.

The use of an unassisted manual sequential gear change mechanism is allowed.

1.6.5 Electronic Controls.

No type or form of electronic control is permitted for the following components: Suspension, Braking, Gear change/clutch, front and rear differentials. Simple engine cut operating during a mechanically activated gear change is permitted.

1.7 ~~Production~~ **PREPARED** 4WD

1.7.1 Definition.

Any AWD or 4WD vehicle which meets the requirements of CARS Technical Rules 1 to 1.4, and 12.7.2 – 12.7.15

1.7.2 Engine.

1.7.2.1 The engine must be derived from the product line offered by the vehicle manufacturer

1.7.3 Turbocharger/Supercharger Restrictions.

Turbocharger and supercharger units must be un-modified OEM for the model.

1.7.4 Body Work.

1.7.4.1 Except for CARS Technical Rule 12.4.1.1 the modification, reinforcement, substitution, addition or deletion of parts and components is permitted without restriction.

1.7.4.2 Width:

- Maximum Width is OEM +10%
- Maximum allowable width is 2000mm including mirrors

1.7.4.3 Wings must be OEM

1.7.5 Mechanical Components

1.7.5.1 Brakes, carburettor/injection, suspension components, cooling, final drive ratio and type, clutch, pressure plate and flywheel are unrestricted.

1.7.5.2 Suspension:

- Rear subframe must remain OEM. Only one suspension point per side may be moved
- Strut/Shock towers may be raised upward no more than 3.5"/89mm in the axis of travel only.
- Pick-up points on the chassis may be reinforced by the way of plating,
- The addition of strut tower braces,
- The substitution of OEM bushings and sway bars,
- Reinforcement of stock control arms.

1.7.5.3 Transmissions.

Any transmission normally installed by the manufacturer for the model and generation may be used, including CVT or dual clutch.

1.7.6 Electronic Controls

No type or form of electronic control is permitted for the following components: suspension, braking, gear change/clutch, front and rear differentials.

1.7.7 Induction.

The carburettor(s) or fuel injection normally installed by the manufacturer must be OEM for the model. The electronic control unit (ECU) for the injection is free. The elements which control the quantity of fuel fed into the engine may be modified, but not those which control the volume of air.

1.7.8 Exhaust.

The exhaust system is free except that the stock exhaust manifold(s) must be retained. The pipe(s) must exit behind the driver and external to the body.

1.8 ~~Production~~ P2WD

1.8.1 Definition.

Any 2WD vehicle which meets the requirements of CARS Technical Rules 1 to 1.4, and 12.8.2 to 12.8 6. This includes vehicles of series or limited production.

1.8.2 Engine.

The engine must be derived from the product line offered by the vehicle manufacturer

1.8.3 Turbocharger/Supercharger Restrictions.

Turbocharger and supercharger units must be un-modified OEM for the model.

1.8.4 Body Work.

1.8.4.1 Except for CARS Technical Rule 12.4.4.2 the modification, reinforcement, substitution, addition or deletion of parts and components is permitted without restriction.

1.8.4.2 Width:

- Maximum Width is OEM +10%
- Maximum allowable width is 2000mm including mirrors

1.8.4.3 Wings must be OEM

1.8.5 Mechanical Components.

Brakes, carburettor/injection, suspension components, cooling, final drive ratio and type, clutch, pressure plate and flywheel are unrestricted.

1.8.5.1 Suspension:

- Rear subframe must remain OEM. Only one suspension point per side may be moved
- Strut/Shock towers may be raised upward no more than 3.5"/89mm in the axis of travel only.
- Pick-up points on the chassis may be reinforced by the way of plating,
- The addition of strut tower braces,
- The substitution of OEM bushings and sway bars,
- Reinforcement of stock control arms.

1.8.5.2 Transmissions.

- Any transmission normally installed by the manufacturer ~~for the model and generation~~ may be used. including CVT or dual clutch.

1.8.6 Electronic Controls.

No type or form of electronic control is permitted for the following components: suspension, braking, gear change/clutch, front and rear differentials.

1.8.7 Induction.

The carburetor(s) or fuel injection normally installed by the manufacturer must be OEM for the model. The electronic control unit (ECU) for the fuel injection is free. The elements that control the quantity of fuel fed into the engine may be modified, but not those that control the volume of air

1.8.8 Exhaust.

The exhaust system is free except that the stock exhaust manifold(s) must be retained. The pipe(s) must exit behind the driver and external to the body.

DRAFT

1.9 VEHICLE LOG BOOKS

- 1.9.1 A standard CARS Vehicle Log Book shall be issued for all vehicles. The log book shall remain with the vehicle, including changes of ownership. CARS retain ownership of the log book which may be withdrawn by the National Scrutineer or Technical Director if the vehicle fails to comply with CARS safety requirements.
- 1.9.2 Only one log book is issued to each vehicle (other than by way of extension or replacement, Misuse of a log book shall be deemed a breach of the GCRs.
- 1.9.3 The CARS Technical Director shall maintain a CARS National Log Book registry. All CARS log books shall be given a unique Log Book identification number by the CARS Technical Director.
- 1.9.4 A Log Book can be issued for a New Build or as a Replacement or Extension of an existing log book as per the following requirements:
- 1.9.4.1 A New build:
- a) The builder/owner shall request, from the CARS Region Director an initial inspection of the completed fixed components including, roll cage, seat rails, seat belt attachments & unibody. An initial inspection may be declined if the above noted parts are painted.
 - b) Prior to inspection, the builder/owner is required to have paid the inspection fee and pre-determined travel expenses (payable directly to the CARS office).
 - c) Expenses will include:
 - Mileage allowance as amended periodically by CRA,
 - Accommodation costs, if applicable,
 - Per diem food and misc. expenses.
 - d) Upon receipt of the fees and expenses the CARS Region Director will arrange for an inspection by a CARS designated inspector. Vehicle inspection and inspector expense fee schedule is posted on the CARS website.
 - e) Upon successful inspection, the CARS designated inspector shall sign off the initial inspection report and submit the completed inspection report to the CARS Technical Director.
 - f) The CARS Technical Director will review the inspection report and assign a CARS log book identification number.
 - g) Prior to the first event, or at the first event with prior approval of the CARS designated inspector, the final inspection
 - h) will be completed and include: both
 - Inspection of all removable and consumable parts for compliance with the NRR's and,
 - Inspection for class compliance as per CARS Technical Rules section 12.

- i) Upon successful final inspection, the CARS designated inspector shall apply the individualized CARS decals to the roll cage and sign off final inspection in the CARS log book.
- j) The vehicle is now approved to compete, subject to event technical inspection.

1.9.4.2 As a Replacement for an existing log book:

- a) If the log book needs replacing, the vehicle owner shall request a replacement log book from the CARS Region Director;
- b) Reinspection of the car may be required by the Technical Director;
- c) If no re-inspection is required, the new log book will be issued by the Technical Director upon receipt of the replacement log book fee (payable directly to the CARS office);
- d) If re-inspection is required, then prior to inspection, the owner is required to have paid the inspection fee and pre-determined expenses (payable directly to the CARS office);
- e) Expenses will include:
 - Mileage allowance as amended periodically by CRA,
 - Accommodation cost, if applicable,
 - Per diem for food and misc. expenses.
- f) Upon receipt of the fee and expenses, the CARS Region Director will arrange for an inspection by a CARS designated inspector;
- g) Replacement log book and re-inspection fee schedule is posted on the CARS website;
- h) The Region Director will communicate the issue of the replacement log book with the CARS Technical Director.

1.9.4.3 Extension for an existing log book

If the log book is full, the vehicle owner shall request an extension book from the CARS Region Director at no cost;

1.9.5 Inspections for issuing a Log Book.

1.9.5.1 Initial inspection.

An initial inspection is required as per the “CARS Initial Log Book Inspection Report” form which is available online at: <https://carsrally.ca/documents/competitors/>

1.9.5.2 Final Inspection.

A final inspection will include items listed in CARS Technical Rule 1.9.4.1.g) above and include a review of the following items:

- Vehicle Color,
- Engine Type and number of cylinders,
- Displacement,

- Naturally Aspirated, Turbocharged or Supercharged,
- Turbo restrictor size,
- Pop-Off Valve required,
- Drive,
- Lights,
- Horn,
- Master switch,
- Fuel Pump cut-off,
- Proof of allowable equipment,
- Seat Type, Installation & expiry dates,
- Belt Type, Installation & expiry dates,
- Fire extinguisher Type, Installation & expiry dates,
- Competition Class approved: O4WD, P4WD, O2WD, P2WD,
- Pictures of Vehicle.

1.9.5.3 Updating of Log Book.

A complete description of the vehicle is to be entered in the places provided. All changes of ownership of the vehicle must be recorded as provided. It is the responsibility of the vehicle owner to submit updated vehicle information such as photographs, colour, class description, etc. in a timely manner.

1.9.6 Use of the Log Book at events.

1.9.6.1 Event Inspection.

Technical Inspectors shall use the “Scrutineering Form” for event technical inspection. The form is available online at: <https://carsrally.ca/documents/organizers/>

1.9.6.2 At each event, the log book must be surrendered to the chief scrutineer at technical inspection with the signature of the driver/entrant for that event in the space provided.

1.9.6.3 During technical inspection, any deviations should be noted by the scrutineer and, at the conclusion of technical inspection the chief scrutineer should give all log books collected to the National Scrutineer or his designate. (Exception: log books must remain with the vehicle if that log book is required by a provincial licensing authority as part of the licensing process.)

1.9.6.4 If a vehicle is protested during an event, the results of this protest must be noted in the log book by the Steward(s).

- 1.9.6.5 If, during an event, the vehicle is involved in an accident or is damaged due to mechanical failure, the damage is to be noted in the Vehicle Log Book by the National scrutineer or his designate.
- 1.9.6.6 It is the responsibility of the entrant to collect the log book at the end of the event. At certain events, it may be required that the Log Book be kept in the vehicle during the competition. In those instances, the Log Book must be handed back to event officials at the final MTC for National Scrutineer and/or Stewards notations.
- 1.9.6.7 SCCA/ARA/NASA Vehicle Log Books are to be accepted at all CARS rallies.
- 1.9.6.8 Failure to present the Vehicle Log Book at scrutineering will result in a \$25.00 fine which must be paid in full before the offending entrant will be allowed to start the event.

DRAFT

DRAFT